

INTERRUPTED WALL FOR POSITION SIZES 6 AND ABOVE
 12

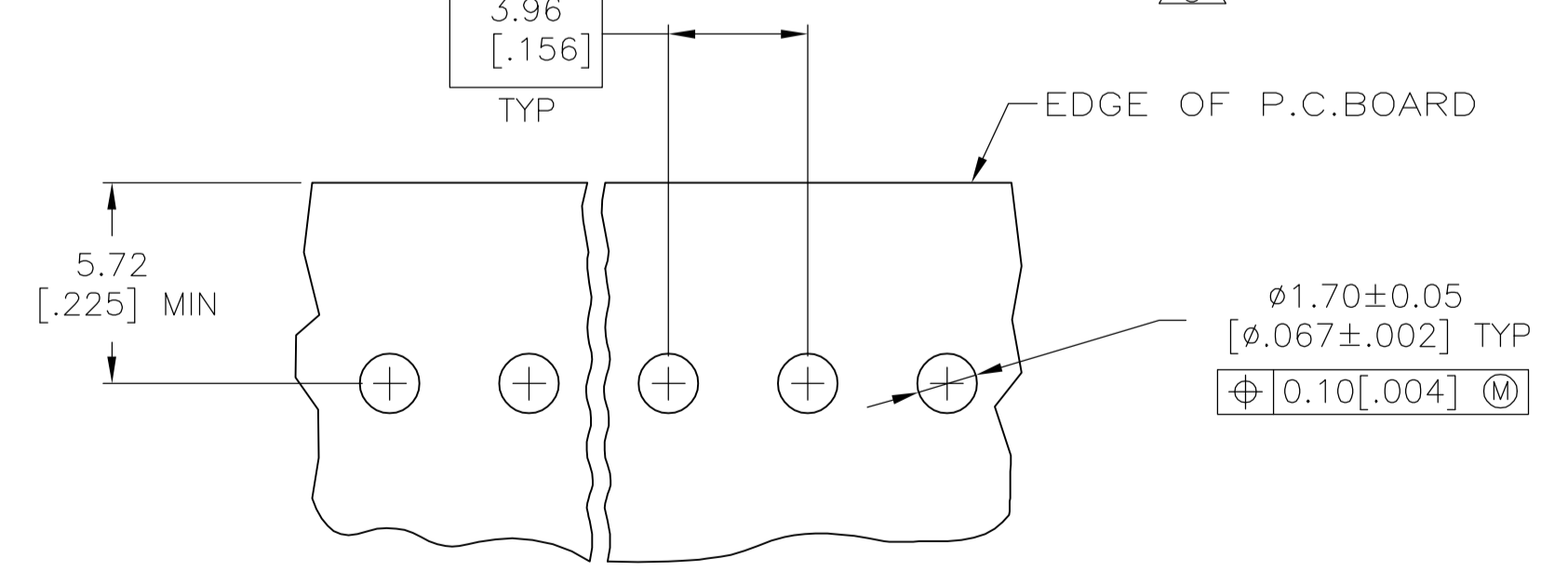

RECOMMENDED MOUNTING HOLE PATTERN FOR 1.57 [.062] THICK P.C. BOARD 10

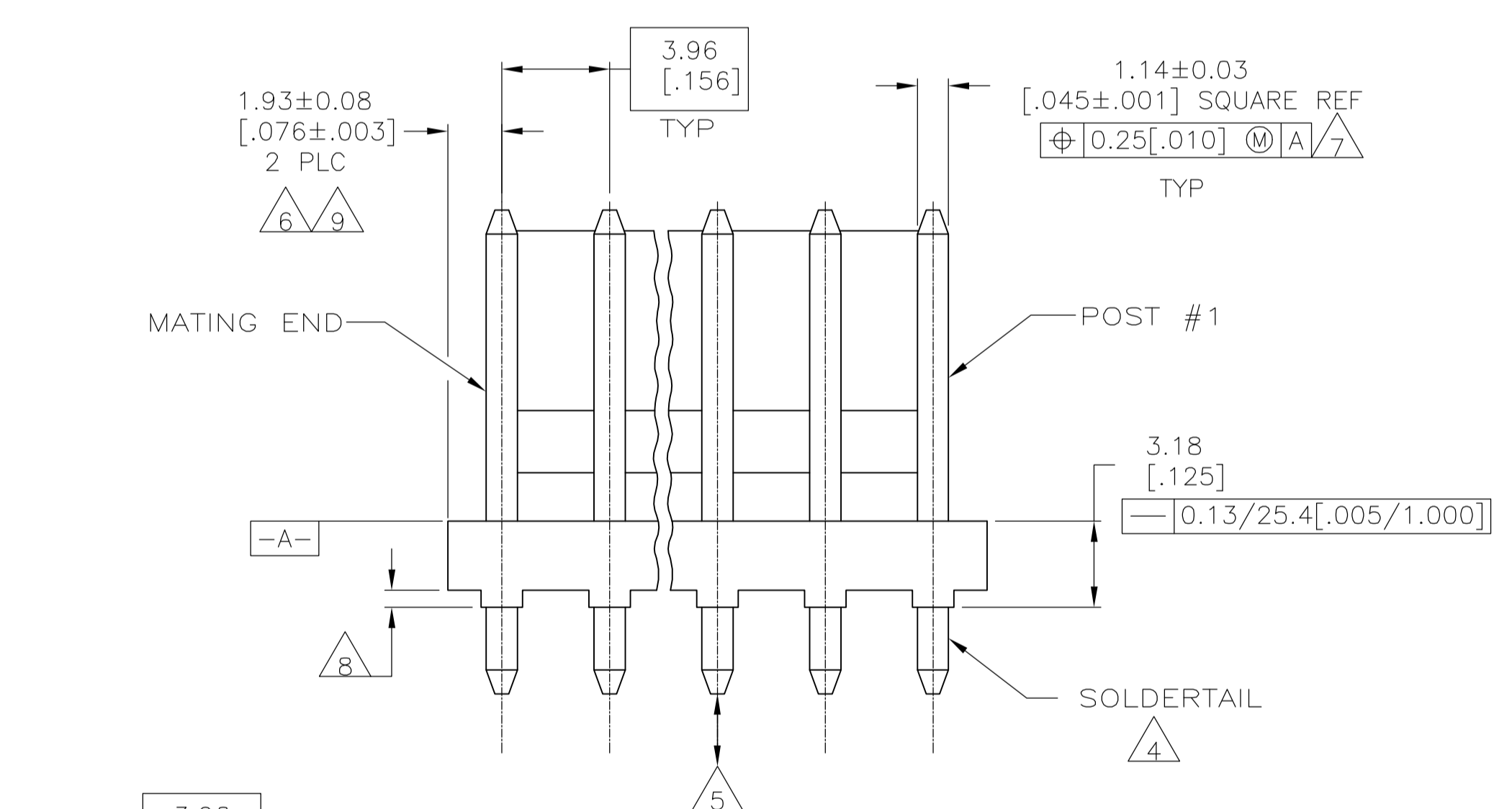
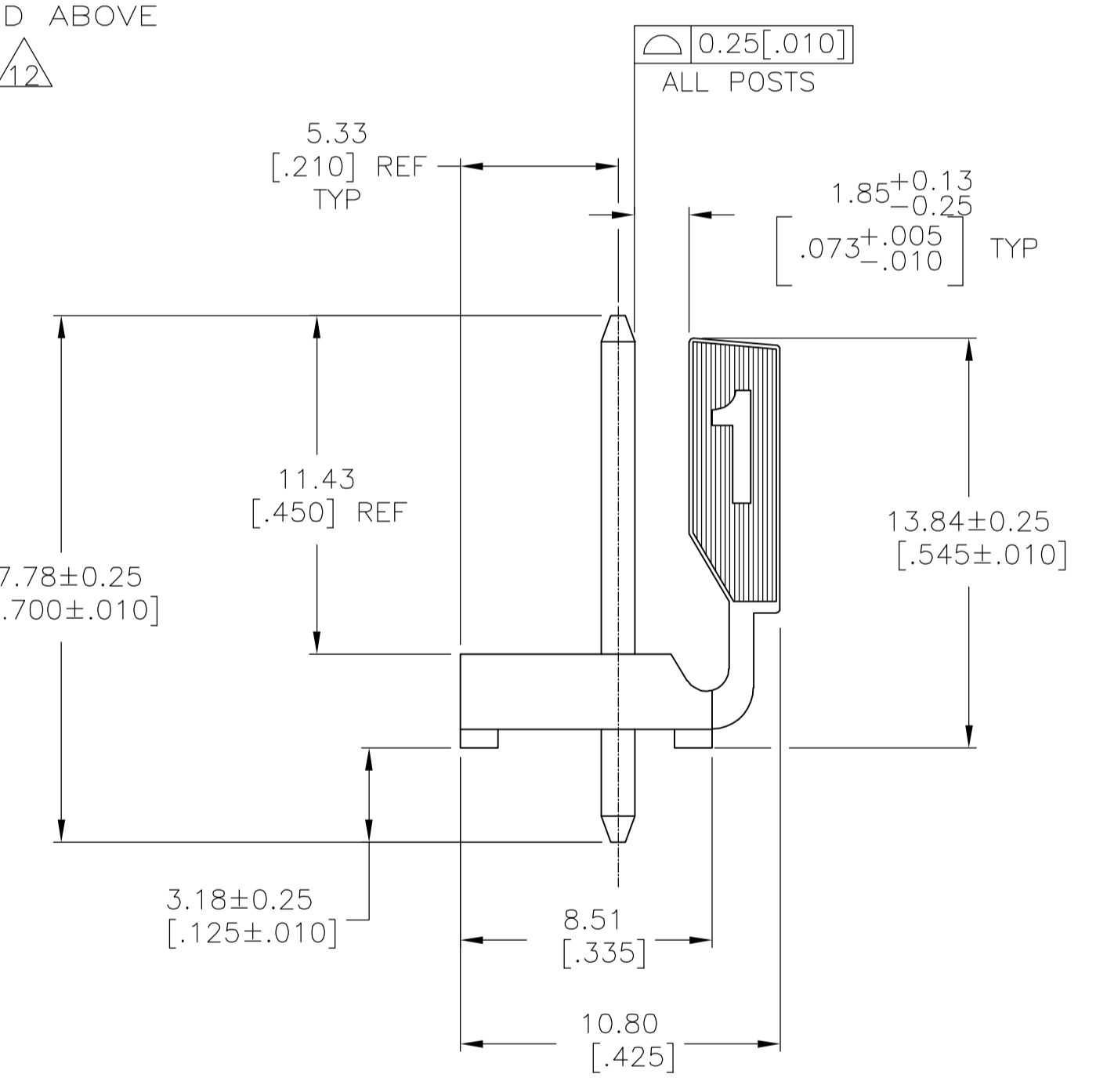

- 1 MATERIAL
HOUSING: THERMOPLASTIC POLYESTER, GLASS FILLED, UL94V-0.
POST: COPPER ALLOY
- 2 FINISH
HOUSING: NATURAL
POST: BRIGHT TIN-LEAD (93/7) PLATE, 0.00380-0.00880 [.000150-.000350] THK OVER NICKEL UNDERPLATE, 0.00130 [.000050] MIN THK.
- 3 UL MARKING MAY NOT APPEAR ON THE 2 OR 3 POSITION SIZES.
CSA MARKING MAY NOT APPEAR ON THE 2 POSITION SIZE.
- 4 POST SOLDERDETAILS COMPLY WITH AMP SOLDERABILITY SPEC 109-11-2.
- 5 POST WITHSTANDS 13.34N [3 LB] MIN AXIAL FORCE IN EITHER DIRECTION WITHOUT DISLODGING.
- 6 APPLIES AT -A- .
- 7 APPLIES WHEN THE HEADER IS STRAIGHT.
- 8 PLASTIC PROJECTIONS PERMITTED IN THIS ZONE.
- 9 COORDINATE DIMENSIONS APPLIES FROM THE CENTER OF THE ACTUAL FEATURE.
- 10 SOLDER SIDE OF BOARD IS SHOWN.
- 11 DIMENSIONS IN BRACKETS ARE IN INCHES.
- 12 ALL POSITION SIZES HAVE THE BACKWALL NOTCHED ON BOTH ENDS AS SHOWN. THE 2 THRU 5 POSITION SIZES HAVE SOLID BACKWALLS. POSITION SIZES 6 AND ABOVE HAVE AN INTERRUPTED BACKWALL AT VARIOUS LOCATIONS (SEE TABLE FOR INTERRUPTION(S) LOCATIONS).
- 13 EDGE OF POLARIZING LOCK WALL TO BE IN LINE WITH CENTERLINE OF ADJACENT POST WITHIN ±0.13 [.005]
- 14 NOTCH SHOWN MAY OR MAY NOT APPEAR.
- 15 FINISH
HOUSING: NATURAL
POST: MATTE TIN PLATE 0.000150 MIN THICK OVER NICKEL .

FINISH	BACKWALL INTERRUPTION(S) BETWEEN POST	L	NO. OF POSITIONS	PART NO.
15	4&5, 7&8, 11&12, 14&15	71.20 [2.803]	18	4-644611-8
15	4&5, 7&8, 10&11, 13&14	67.23 [2.647]	17	4-644611-7
15	4&5, 8&9, 12&13	63.27 [2.491]	16	4-644611-6
15	4&5, 8&9, 11&12	59.31 [2.335]	15	4-644611-5
15	4&5 7&8, 10&11	55.35 [2.179]	14	4-644611-4
15	4&5 7&8, 10&11	51.38 [2.023]	13	4-644611-3
15	4&5, 8&9	47.42 [1.867]	12	4-644611-2
15	4&5, 7&8	43.46 [1.711]	11	4-644611-1
15	3&4, 7&8	39.50 [1.555]	10	4-644611-0
15	3&4, 6&7	35.53 [1.399]	9	3-644611-9
15	4&5	31.57 [1.243]	8	3-644611-8
15	4&5	27.61 [1.087]	7	3-644611-7
15	3&4	23.65 [.931]	6	3-644611-6
15	NONE	19.69 [.775]	5	3-644611-5
15	NONE	15.72 [.619]	4	3-644611-4
15	NONE	11.76 [.463]	3	3-644611-3
15	NONE	7.80 [.307]	2	3-644611-2
2	4&5, 7&8, 11&12, 14&15	71.20 [2.803]	18	1-644611-8
2	4&5, 7&8, 10&11, 13&14	67.23 [2.647]	17	1-644611-7
2	4&5, 8&9, 12&13	63.27 [2.491]	16	1-644611-6
2	4&5, 8&9, 11&12	59.31 [2.335]	15	1-644611-5
2	4&5 7&8, 10&11	55.35 [2.179]	14	1-644611-4
2	4&5 7&8, 10&11	51.38 [2.023]	13	1-644611-3
2	4&5, 8&9	47.42 [1.867]	12	1-644611-2
2	4&5, 7&8	43.46 [1.711]	11	1-644611-1
2	3&4, 7&8	39.50 [1.555]	10	1-644611-0
2	3&4, 6&7	35.53 [1.399]	9	644611-9
2	4&5	31.57 [1.243]	8	644611-8
2	4&5	27.61 [1.087]	7	644611-7
2	3&4	23.65 [.931]	6	644611-6
2	NONE	19.69 [.775]	5	644611-5
2	NONE	15.72 [.619]	4	644611-4
2	NONE	11.76 [.463]	3	644611-3
2	NONE	7.80 [.307]	2	644611-2



THIS DRAWING IS A CONTROLLED DOCUMENT.

DIMENSIONS: mm [INCHES]	TOLERANCES UNLESS OTHERWISE SPECIFIED:	DIN L SMITH 03DEC93	tyco Electronics Tyco Electronics Corporation Harrisburg, Pa 17105-3608
0 PLC ± .01	1 PLC ± .01	CHK R SWING 03DEC93	NAME D CLARK 15DEC93
2 PLC ± .01	3 PLC ± .01	APVD D CLARK 15DEC93	PRODUCT SPEC
4 PLC ± .01	ANGLES ± .01	APPLICATION SPEC	MTA-156 HEADER ASSEMBLY, POLARIZED LOCK, STRAIGHT, .045 SQUARE POST, TIN-LEAD PLATED, WITHOUT RETENTION PEGS
MATERIAL 1	FINISH 2	WEIGHT	SIZE A1 00779 C=644611
CUSTOMER DRAWING		SCALE 5:1	SHEET 1 OF 1 REV H1